



## Atlas Copco Boltec M2C

Available for  
hire.

Short or Long  
term use.

Mine Site or  
Civil Project.

Contact Jemrok  
today.



## Boltec M2C Capabilities

- Highly productive ground support installation for mining, rehabilitation or tunnelling
- 10 bolt carousel
- Adjustable boom for Bolt lengths from 1.5 – 3.5m
- Able to install resin bolts, point anchor bolts, friction bolts
- Face plate dimensions of 150mm square or 200mm round
- 1000V Electric rig

## M2C Dimensions

- Length : 13,405 mm
- Width : 2,245 mm
- Height : 3,021 mm
- Ground clearance : 254 mm
- Weight : 21.6 tonne
- Minimum drive profile : 4,200 mm High by 4,200 mm Wide
- Maximum back height : 8,700 mm

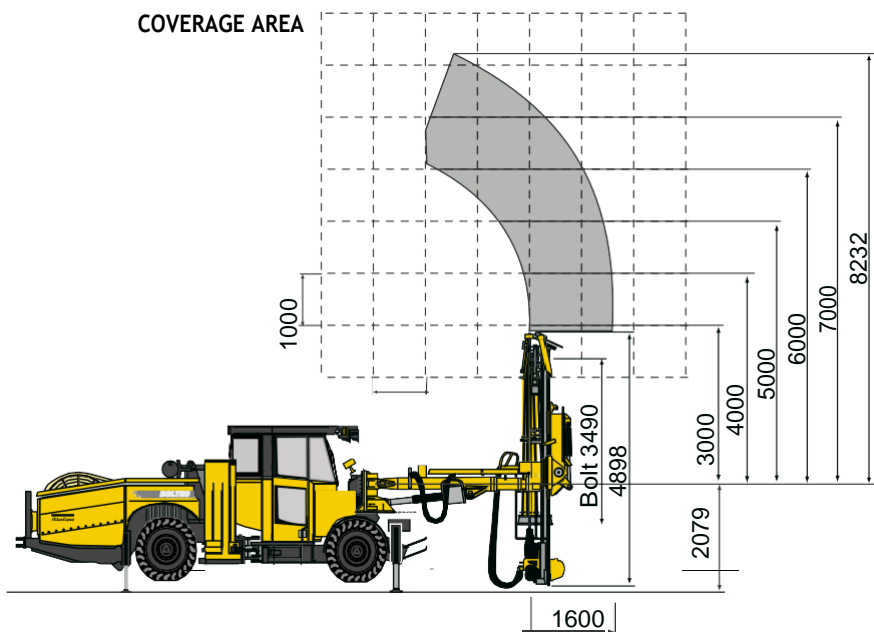

## Contact Us

Scott St Clair

Operations Manager

ph: 03 6442 2699

m: 0439 321 738

e: [scott@jemrok.com.au](mailto:scott@jemrok.com.au)